

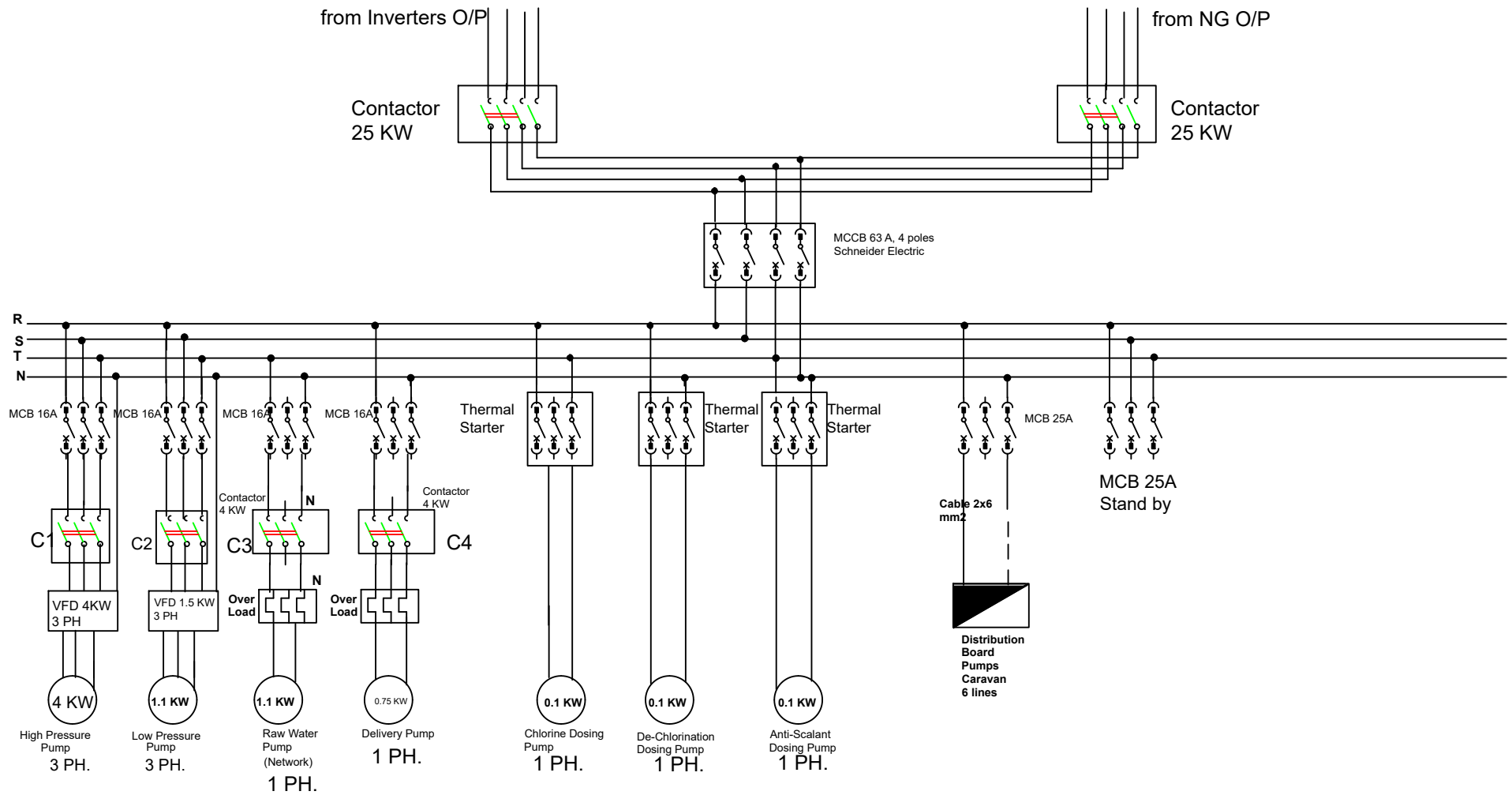

 Contracting Authority : ICRC - CICR IRAQ BAGHDAD Delegation	Designer : Eng. : Saleem Khaleel AL-Qaiem	Location : Bzibiz Settlement Coords : <b>Sector 3</b>	Project name : Bzeibiz Settlement	Scale				
	Position : WatHab Electrical Engineer	Location : AL-Anbar Gov.	Title :Single power Diagram for sector 3	Rev Des	Date	Approval	Signature	
	E-mail : Skhaleelkareemhassn@icrc.org			1	15.02.2026			<b>A01</b>
	mobile : +964(0)7801432957			2				
				3				
			4					



 Contracting Authority : ICRC - CICR IRAQ BAGHDAD Delegation	Designer : Eng. : Saleem Khaleel AL-Qaiem	Location : Bzibiz Settlement	Project name : Bzeibiz Settlement	Scale		<h1 style="text-align: center;">AO2</h1>			
	Position : WatHab Electrical Engineer	Coords : <b>Sector 3</b>	Title: Power Diagram for (MCP) Sector 3	Rev	Des.		Date	Approval	Signature
	E-mail : Skhaleelkareemhassn@icrc.org	Location : AL-Anbar Gov.	1	3.3.2026					
	mobile : +964(0)7801432957		2						
			3						
		4							

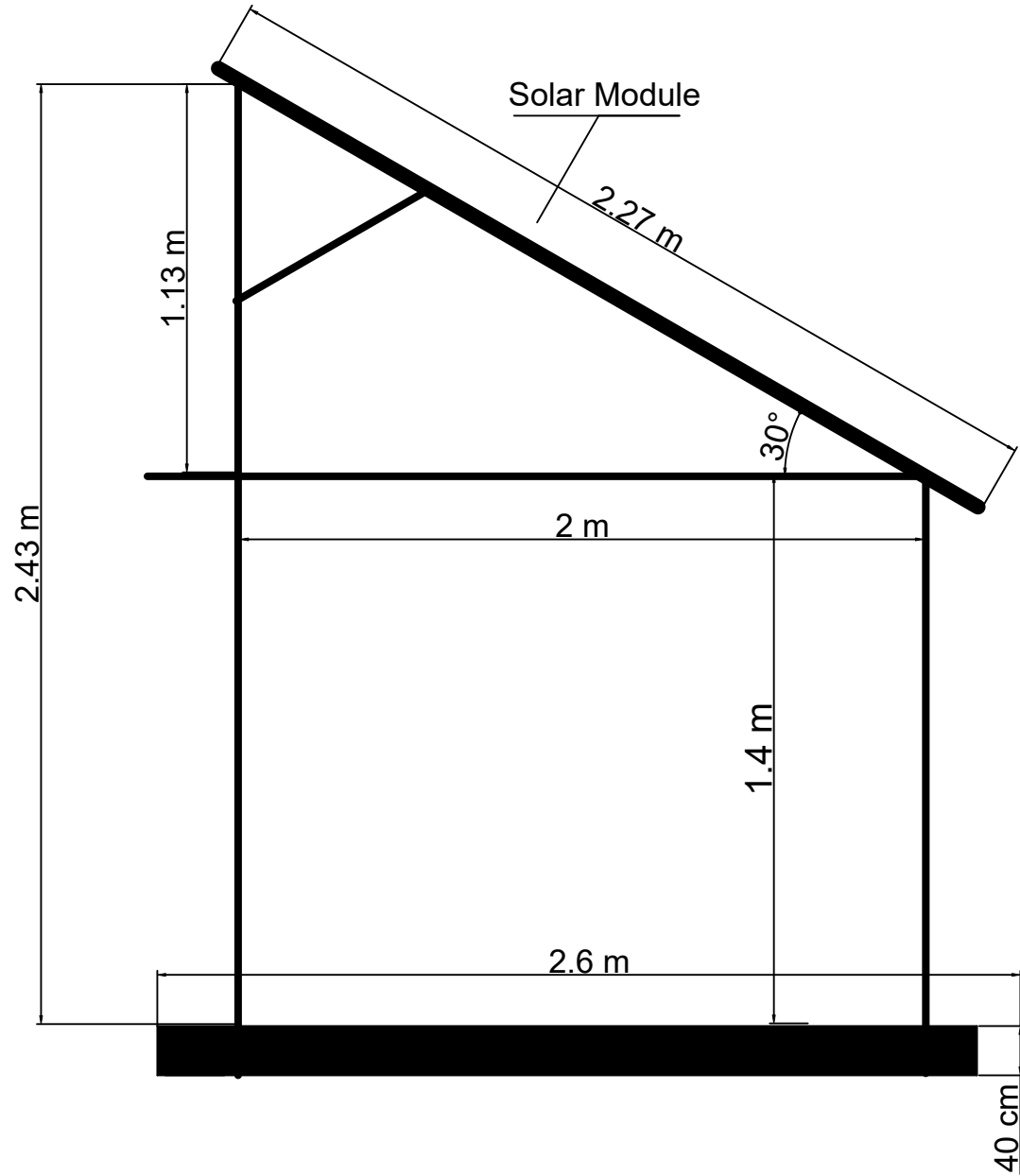

 Contracting Authority : ICRC - CICR IRAQ BAGHDAD Delegation	Designer : Eng. : Saleem Khateel AL-Qalem Position : WattHab Electrical Engineer E-mail : Skhateelkareemhassen@icrc.org mobile : +964(0)7801432957	Location : Bzeibiz Coords : Settelement Location : AL-Anbar Gov.	Project name : Bzeibiz Settelement Title : Structure with Concrete bases (sector 3 )	Scale		Approval Signature	<b>A03</b>															
			<table border="1"> <thead> <tr> <th>Rev</th> <th>Des</th> <th>Date</th> </tr> </thead> <tbody> <tr> <td>1</td> <td></td> <td>09.02.2026</td> </tr> <tr> <td>2</td> <td></td> <td></td> </tr> <tr> <td>3</td> <td></td> <td></td> </tr> <tr> <td>4</td> <td></td> <td></td> </tr> </tbody> </table>	Rev	Des			Date	1		09.02.2026	2			3			4				
	Rev	Des	Date																			
	1		09.02.2026																			
	2																					
3																						
4																						

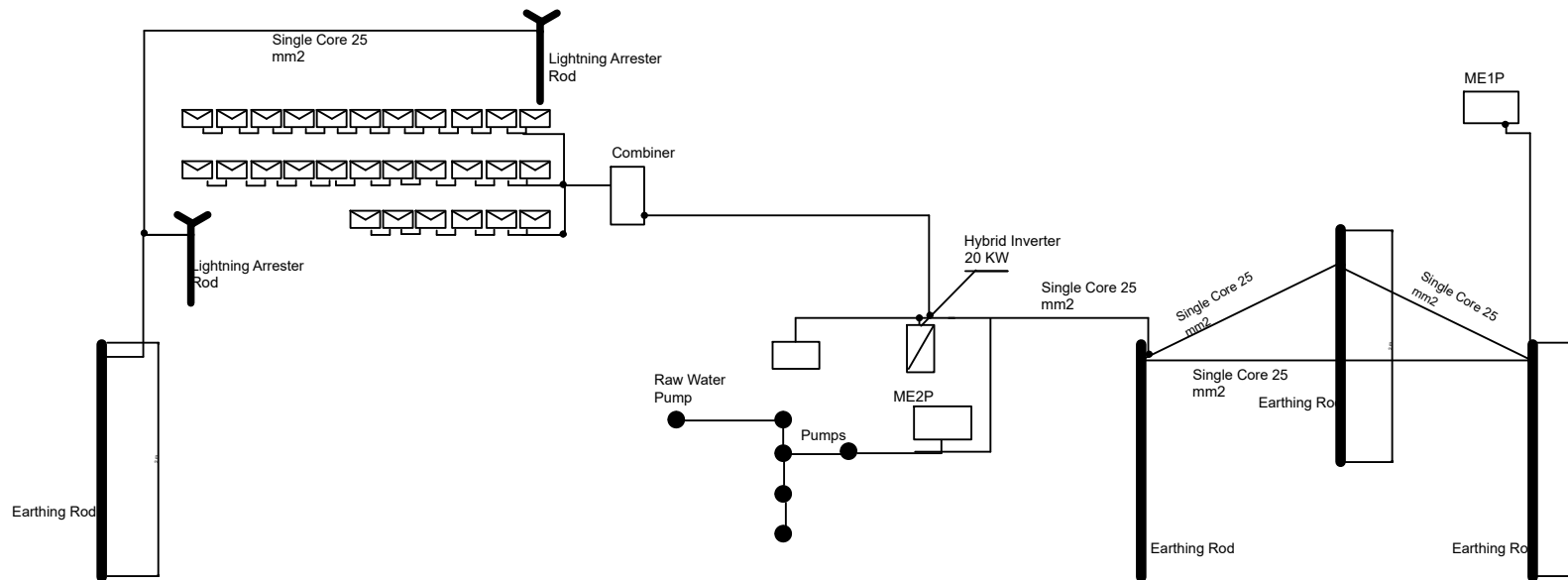

 Contracting Authority : ICRC - CICR IRAQ BAGHDAD Delegation	Designer : Eng. : Saleem Khaleel AL-Qalem Position : WatHab Electrical Engineer E-mail : Skhaleelkareemhassn@icrc.org mobile : +964(0)7801432957	Location : Bzibiz Settlement Coords : Location : AL-Anbar Gov.	Project name : Bzeibiz Settlement Title : Earthing System and Lightning Arresters for Sector 3	Scale		Approval	Signature	A04	
				Rev	Des.				Date
				1					3.3.2026
				2					
				3					
4									

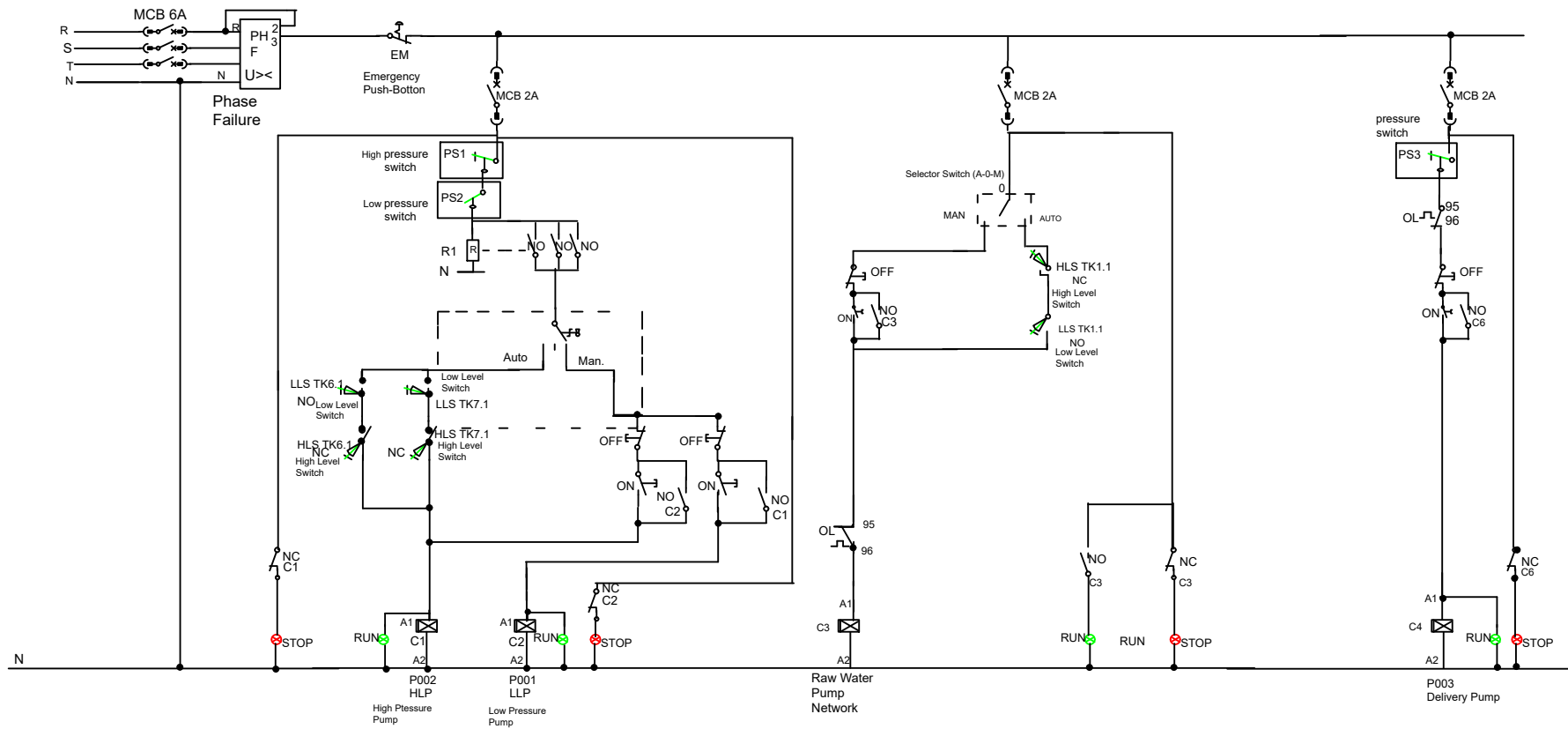

 <p>Contracting Authority : ICRC - CICR IRAQ BAGHDAD Delegation</p>	<p>Designer : Eng. : Saleem Khaleel AL-Qaiem</p> <p>Position : WatHab Electrical Engineer</p> <p>E-mail : Skhaleelkareemhassn@icrc.org</p> <p>mobile : +964(0)7801432957</p>	<p>Location : <b>Bzeibiz Settelment</b></p> <p>Coords : Governorate: AL-Anbar Gov.</p>	<p>Project name : <b>Bzeibiz Settelment / Rehabilitation</b></p> <p>Title : Control Diagram</p>	Scale			<p>Approval</p> <p>Signature</p> <p style="font-size: 2em; text-align: center;">A05</p>
				Rev	Des.	Date	
				1		06.08.2025	
				2			
				3			
4							

# Performance of grid-connected PV

PVGIS-5 estimates of solar electricity generation:

## Provided inputs:

Latitude/Longitude: 33.157,44.020  
 Horizon: Calculated  
 Database used: PVGIS-SARAH3  
 PV technology: Cryst Sil Original  
 PV installed: 15.1 kWp  
 System loss: 14 %

## Simulation outputs

Slope angle: 31 (opt) °  
 Azimuth angle: 0 °  
 Yearly PV energy production: 24943.03 kWh  
 Yearly in-plane irradiation: 2231.25 kWh/m<sup>2</sup>  
 Year-to-year variability: 520.50 kWh  
 Changes in output due to:  
 Angle of incidence: -2.55 %  
 Spectral effects: -0.33 %  
 Temperature and low irradiance: -11.37 %  
 Total loss: -25.97 %

## Outline of horizon at chosen location:

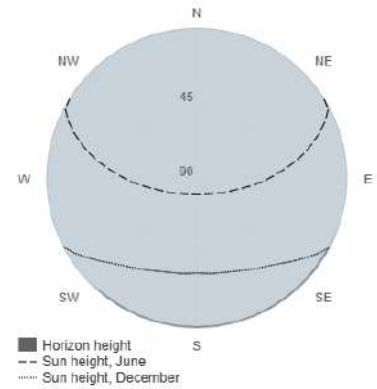

## Monthly energy output from fix-angle PV system:

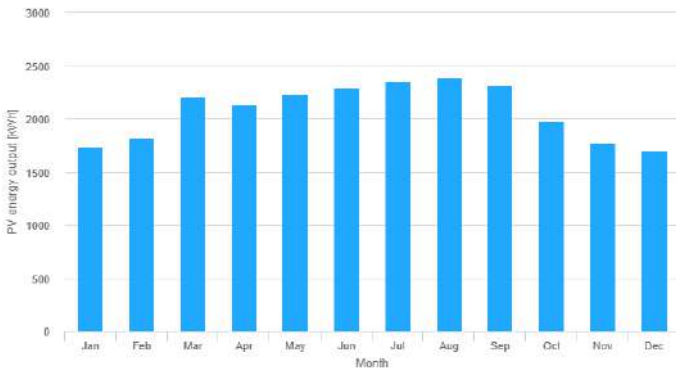

## Monthly in-plane irradiation for fixed-angle:

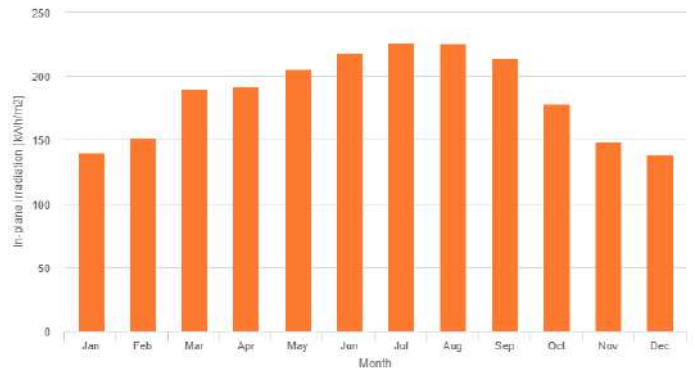

## Monthly PV energy and solar irradiation

Month	E_m	H(i)_m	SD_m
January	1734.5	140.4	123.1
February	1826.3	151.5	176.1
March	2204.7	190.3	121.3
April	2133.7	192.3	124.7
May	2236.0	205.8	131.0
June	2289.0	218.3	61.5
July	2354.6	226.6	51.2
August	2388.7	226.1	53.0
September	2313.8	214.5	82.8
October	1985.0	178.1	179.0
November	1778.0	149.1	213.6
December	1698.7	138.3	141.1

E\_m: Average monthly electricity production from the defined system [kWh].

H(i)\_m: Average monthly sum of global irradiation per square meter received by the modules of the given system [kWh/m<sup>2</sup>].

SD\_m: Standard deviation of the monthly electricity production due to year-to-year variation [kWh].